



Table of Contents

EN

Description	5
Main components	5
Name plate	6
Function	7
Multi-section	8
Multi-pass	9
Identification of plate side	9
Installation	10
Before installation	10
Requirements	11
Lifting	12
Raising	13
Mounting of stands	14
Operation	15
Start-up	15
Unit in operation	16
Shut-down	16
Maintenance	17
Cleaning – Product side	17
Cleaning – Non-product side	19
Opening and closing	20
Regasketing	24

Original instructions

© COPYRIGHT Alfa Laval Lund AB, 2012

How to contact Alfa Laval

Contact details for all countries are continually updated on our website.

Please visit www.alfalaval.com and contact your local Alfa Laval representative.



EN Preface

This manual provides information needed to install, operate and carry out maintenance of the plate heat exchanger (PHE).

Safety considerations

The plate heat exchanger shall be used and maintained in accordance with Alfa Laval's instructions in this manual. The incorrect handling of the plate heat exchanger may result in serious consequences with injuries to persons and/or property damage. Alfa Laval will not accept responsibility for any damage or injury resulting from not following the instructions in this manual.

The plate heat exchanger shall be used in accordance with the specified configuration of material, media types, temperatures and pressure for the specific plate heat exchanger.

The following models are covered in this manual:

- Clip 3
- Front 6
- Front 8
- Front 10
- Front 15

Definitions of expressions

**Warning!**

WARNING indicates a potentially hazardous situation which, if not avoided, could result in death or serious injury.

**Caution!**

CAUTION indicates a potentially hazardous situation which, if not avoided, may result in minor or moderate injury.

Note!

NOTE indicates a potentially hazardous situation which, if not avoided, may result in property damage.

PHE drawings

The PHE drawings mentioned in the manual are the drawings included in the delivery of the plate heat exchanger.

Warranty conditions

The warranty conditions are usually included in the signed sales contract prior to the order of the delivered PHE. Alternatively, the warranty conditions are included in the sales offer documentation or with a reference to the document specifying the valid conditions. If faults occur during the specified warranty period, always consult your local Alfa Laval representative for advice.

Report the date when the plate heat exchanger was put into operation to the local Alfa Laval representative.

Advice

Always consult your local Alfa Laval representative for advice on

- New plate pack dimensions if you intend to change the number of plates
- Selection of gasket material if operating temperatures and pressures are permanently changed, or if another medium is to be processed in the PHE.

Storage of the PHE

Alfa Laval delivers the PHE ready to be put into service upon arrival, if nothing else has been agreed. Nevertheless, keep the PHE in the packing box until installation.

If storing for longer periods of time, such as one month or longer, certain precautions should be made to avoid unnecessary damage to the PHE.

Note!

Alfa Laval and its representatives reserve the right to inspect the storage space and/or equipment whenever necessary until the expiration of the warranty period stipulated in the contract. Notification must be given 10 days prior to the date of inspection.

If there is any uncertainty about the storage of the PHE, consult an Alfa Laval representative.

Storage in packing box

If storage of the PHE after delivery is known in advance, inform Alfa Laval when ordering the PHE to ensure that it will be properly prepared for storage before packing.

Indoor storage

- Storage inside a room with a temperature of between 15 and 20 °C (60–70 °F) and humidity around 70 %. For outdoor storage read [“Outdoor storage” on this page](#).
- To prevent damage to the gaskets, there should be absolutely no ozone-producing equipment in the room such as electric motors or welding equipment.
- To prevent damage to the gaskets, do not store organic solvents or acids in the room and avoid direct sunlight, intensive heat radiation or ultraviolet radiation.
- The tightening bolts should be well covered with a light grease coating.

Outdoor storage

If the PHE has to be stored outdoors, all the precautions stated in section [“Indoor storage” on this page](#) should be followed. Protection against the climate is also very important.

The stored PHE shall be visually checked every third month. The check includes:

- Greasing of the tightening bolts
- Metal port covers
- Protection of the plate pack and gaskets

Taken out of service

If, for any reason, the PHE is shut down and taken out of service for a long period of time, follow the same advice as in the previous section [“Indoor storage” on this page](#). However, before storage the following actions must be done.

- Check the measurement of the plate pack (measure between the frame and pressure plates, A dimension).
- Drain both media sides of the PHE.
- Depending on media the PHE should be rinsed and then dried.
- The connection should be covered if the piping system is not connected. Use a plastic or plywood cover for the connection.
- Cover the plate pack with non-transparent plastic film.

Installation after long time storage

If the PHE has been taken out of service for an extensive period of time, longer than one year, the risk of leakage when starting up increases. To avoid this problem, it is recommended to let the gasket rubber rest to regain most of its elasticity.

1. If the PHE is not in position, follow the instructions [“Installation” on page 10](#).
2. Note down the measurement between the frame and pressure plates (A dimension).
3. Remove the feet attached to the pressure plate.
4. Loosen the tightening bolts. Follow the instruction [“Opening” on page 20](#). Open the PHE until the measurement is 1.25A.
5. Leave the PHE for 24-48 hours, the longer the better, for gaskets to relax.
6. Re-tighten according to instruction [“Closing” on page 23](#) or [“Pressure test after maintenance” on page 24](#).
7. Alfa Laval recommends a hydraulic test to be carried out. The media, usually water, should be entered at intervals to avoid sudden shocks to the PHE. It is recommended to test up to the Design Pressure, refer to the PHE drawing.



Environmental compliance

Alfa Laval endeavours to perform its own operations as cleanly and efficiently as possible, and to take environmental aspects into consideration when developing, designing, manufacturing, servicing and marketing its products.

Unpacking

Packing material consists of wood, plastics, cardboard boxes and in some cases metal straps.

- Wood and cardboard boxes can be reused, recycled or used for energy recovery.
- Plastics should be recycled or burnt at a licensed waste incineration plant.
- Metal straps should be sent for material recycling.

Maintenance

- All metal parts should be sent for material recycling.
- Oil and all non-metal wear parts must be taken care of in accordance with local regulations.

Scrapping

At end of use, the equipment shall be recycled according to relevant, local regulations. Besides the equipment itself, any hazardous residues from the process liquid must be considered and dealt with in a proper manner. When in doubt, or in the absence of local regulations, please contact the local Alfa Laval sales company.

Description

Main components

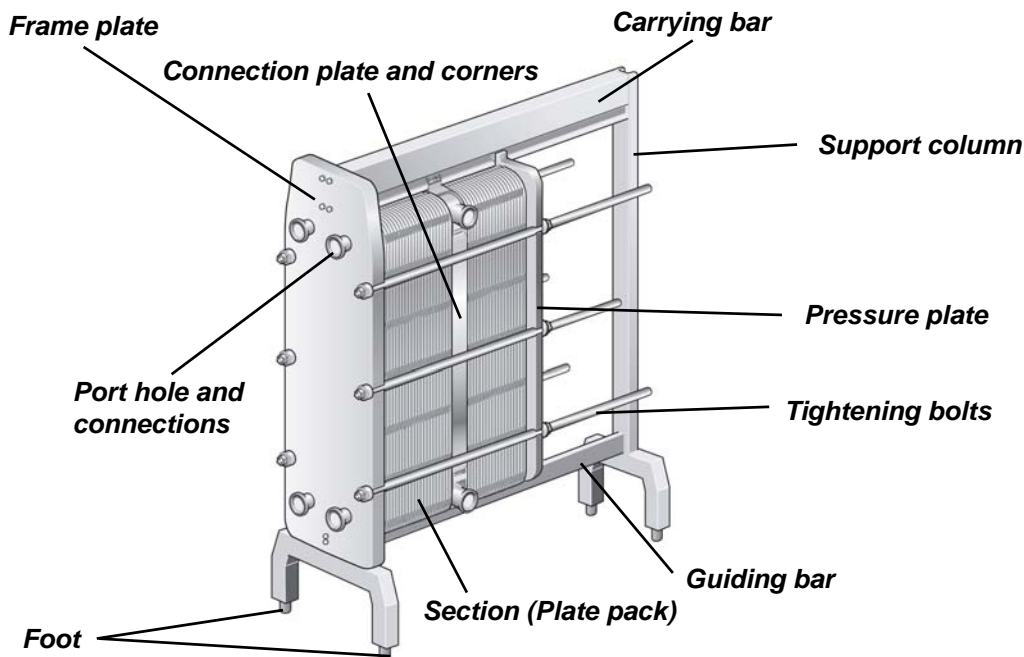

Definition

Bolt protection	Plastic tubes that protect the threads of the tightening bolts.
Carrying bar	Carries the plate pack, connection plates and the pressure plate.
Connection plate and corners	Plate used to separate two or more services in one plate heat exchanger. The plate pack performing such a service is called a section.
Section	When using connection plates, the plate heat exchanger will contain several sections (plate packs).
Foot	Adjustable feet.
Frame plate	Fixed plate with a various number of port holes for the connection of the piping system. The carrying and guiding bars are attached to the frame plate.
Guiding bar	Keeps the channel plates, connection plates and the pressure plate aligned at their lower end.
Plate pack	Heat is transferred from one media to the other through the plates. The plate pack consists of channel plates, end plates, gaskets and, in some cases, transition plates. The measurement of the plate pack is the A dimension, i.e. the measurement between the frame and pressure plates. Refer to the PHE drawing.
Port holes and connections	Port holes through the frame plate allow the media to enter into or exit from the plate heat exchanger. The PHE can be equipped with different connection types, such as flanged. For details, refer to the PHE drawings. Equipped with sanitary fittings, permitting the media to enter into the plate heat exchanger. Inlet or outlet opening in the channel plate, most plates have four ports.
Pressure plate	Moveable plate that can contain a various number of port holes for the connection of the piping system.
Protection sheets	Cover the plate pack and protect against the leakage of hot or aggressive fluids and the hot plate pack.
Support column	Supports carrying and guiding bars.
Tightening bolts	Compress the plate pack between the frame and pressure plates.



Name plate

The type of unit, manufacturing number and manufacturing year can be found on the name plate. Pressure vessel details in accordance with the applicable pressure vessel code are also given. The name plate is fixed to the frame plate, most common, or the pressure plate.





Warning!
The mechanical design pressures and temperatures for each unit are marked on the name plate. These must not be exceeded.

The mechanical design pressure and the design temperature, as given on the name plate, are the values against which the plate heat exchanger is approved according to the pressure vessel code in question. The mechanical design temperature may exceed the operating temperature for which the gaskets have been selected to withstand during their lifetime. If the operating temperatures as specified on the assembly drawing are to be exceeded, the supplier should be consulted.

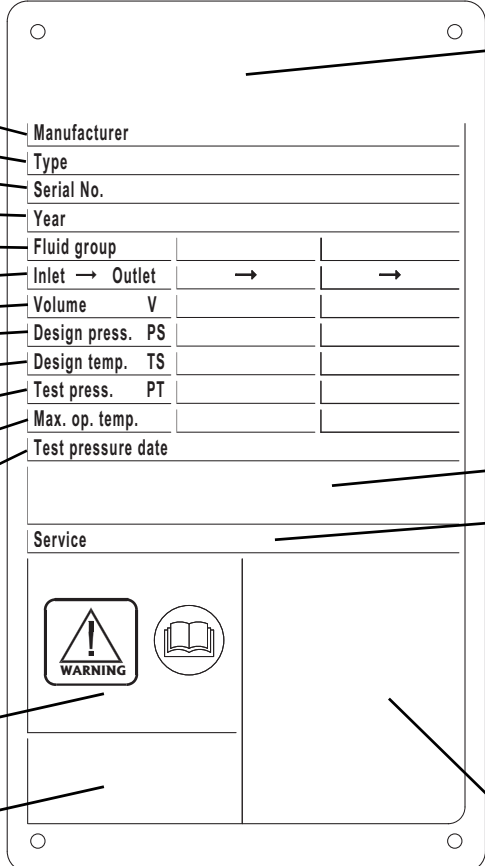
1. Space for logotype.
2. Open space.
3. Website for service.
4. Drawing of possible locations of connections.
Location of 3A tag for 3A units.
5. Space for mark of approval.
6. Warning, read manual.
7. Date of pressure test.
8. Maximum operating temperatures.
9. Test pressure.
10. Max permissible operating temperatures.
11. Max permissible operating pressures.
12. Decisive volume or volume for each fluid.
13. Locations of the connections for each fluid.
14. Decisive fluid group.
15. Year of manufacture.
16. Serial number.
17. Type.
18. Manufacturer's name.



18	Manufacturer		
17	Type		
16	Serial No.		
15	Year		
14	Fluid group		
13	Inlet → Outlet	→	→
12	Volume V		
11	Design press. PS		
10	Design temp. TS		
9	Test press. PT		
8	Max. op. temp.		
7	Test pressure date		
Service			
6			
5			

Function

EN

The plate heat exchanger (PHE) consists of a pack of corrugated metal plates with port holes for the input and output of the two separate fluids. The heat transfer between the two fluids will take place through the plates.

The plate pack is assembled between a frame plate and a pressure plate and compressed by tightening bolts. The plates are fitted with a gasket which seals the channel and directs the fluids into alternate channels. The plate corrugation promotes fluid turbulence and supports the plates against differential pressure.

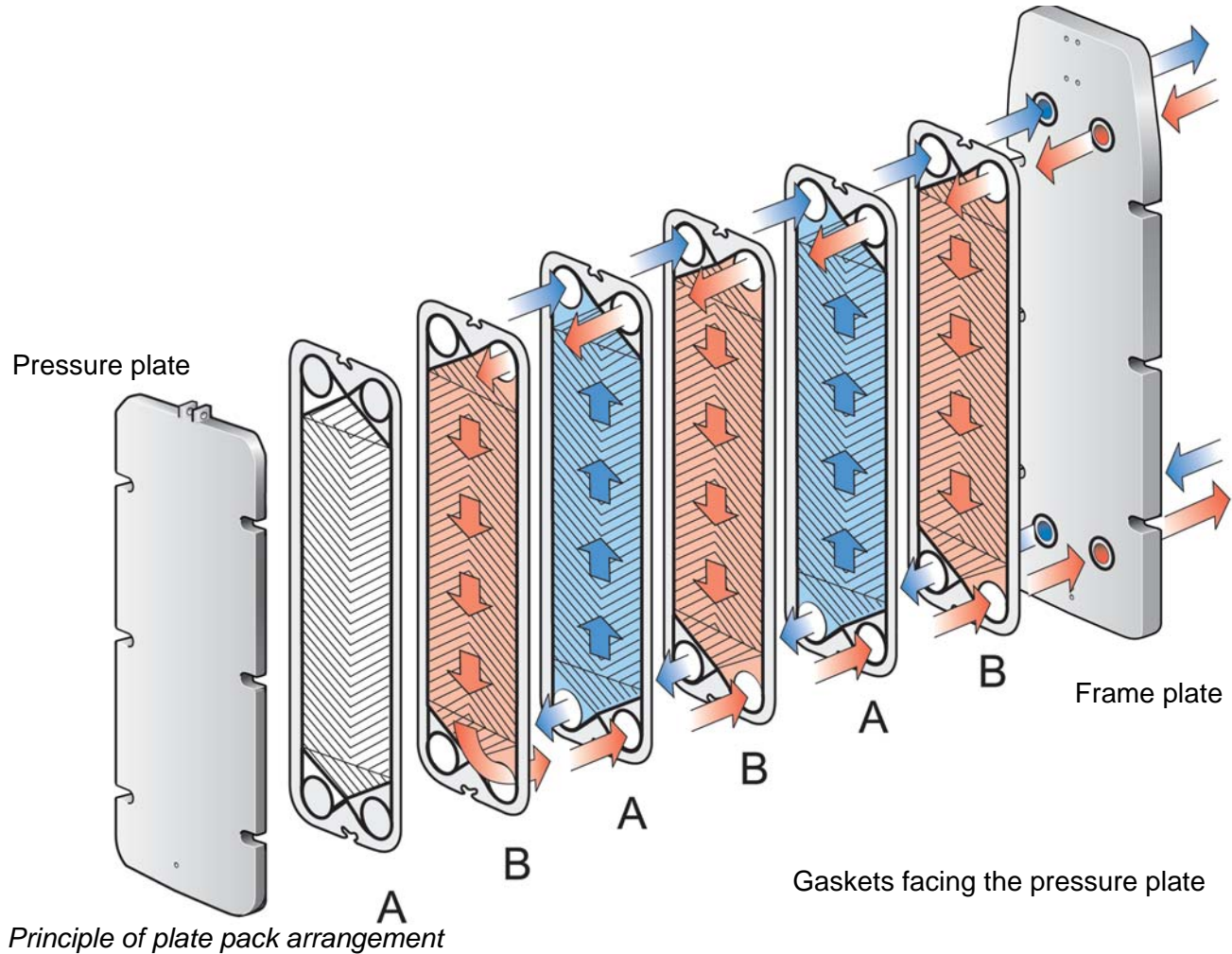



Multi-section

A multi-section PHE can be set up by using connection plates. An example of multi-section configuration is when a media needs to be heated in one stage and then cooled down in the next stage.

Each of the connection plates can be configured by selecting different kinds of corner connections such as double or single corners, passthrough or blinds.

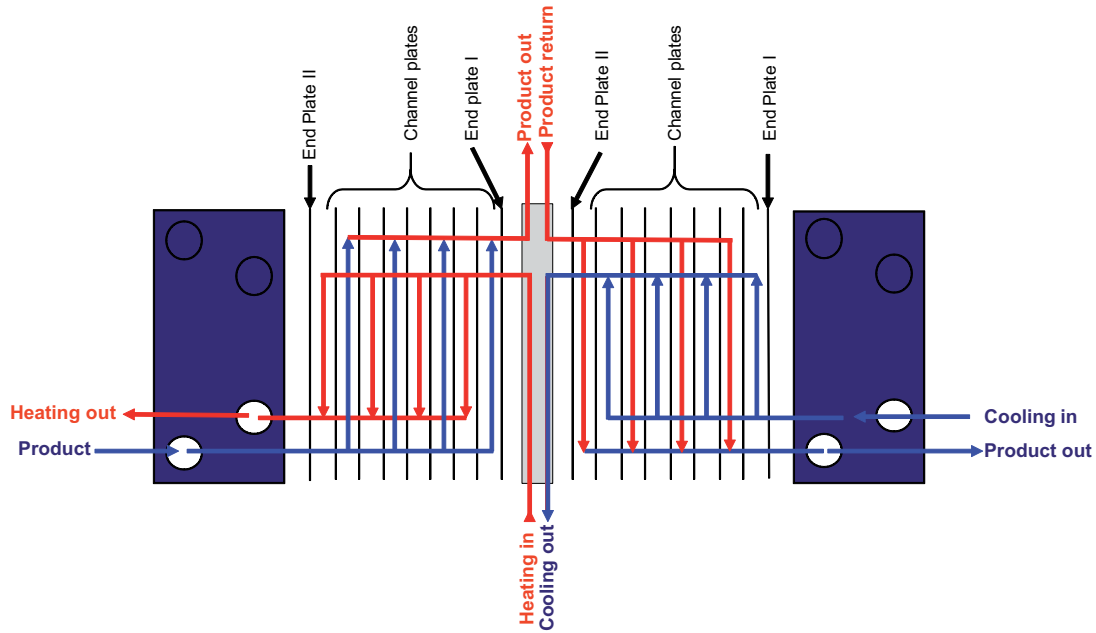

Example of a multi-section set up.

Multi-pass

EN

Multi-pass sections can be created by using turning plates, with 1, 2 or 3 unholed ports. The main purpose is to change the flow direction of one or both fluids.

For some units, a partition plate is required to support the unholed ports in the turning plates. A transition plate also needs to be added to the pack to prevent

media from coming into contact with the partition or pressure plate.

An example of where multi-pass can be used is in processes that require longer heating periods if the media requires slower heating.

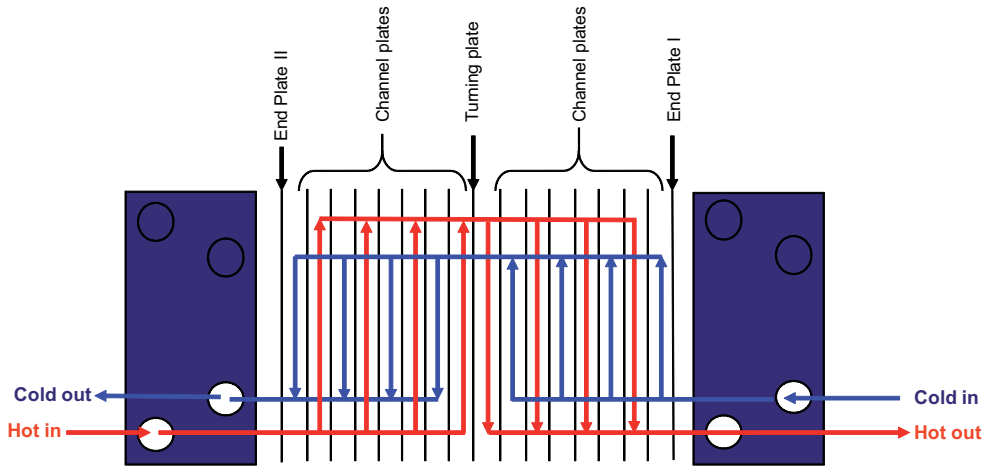

Example of a multi-pass set up.

Identification of plate side

Identification stamp



The A side of the plate is identified by the stamp with the letter A or the model name, in some cases both, at the top of the plate (refer to figure).



EN Installation

Before installation

To consider before installation

- Before connecting any piping, make sure all foreign objects have been flushed out of the piping system that should be connected to the PHE.
- Before start-up, check that all the tightening bolts are firmly tightened and that the plate pack has the correct measurements, refer to the PHE drawing.
- When connecting the piping system, make sure the pipes do not subject the PHE to stress or strain.
- To avoid water hammer, do not use fast-closing valves.
- In automated installations, the stopping and starting of pumps and actuation of valves should be programmed so that the resulting amplitude and frequency of the pressure variation will be as low as possible.
- If pressure variance is expected, install efficient dampers.
- Make sure that no air remains within the PHE.
- Safety valves shall be installed according to current pressure vessel regulations.
- It is recommended that protection sheets are used to cover the plate pack. Protect against the leakage of hot or aggressive fluids and the hot plate pack.
- Design pressures and temperatures for each model are marked on the identification plate. These shall not be exceeded.

Requirements

Space

A minimum free space is needed for lifting plates in and out. Refer to the delivered PHE drawing.

Foundation

Install on a flat foundation giving enough support to the frame.

Elbow

To make it easier to disconnect the PHE, an elbow should be fitted to the connection in the pressure plate, directed upwards or sideways, and with another flange located just outside the contour of the plate heat exchanger.

Shut-off valve

To be able to open the PHE, shut-off valves should be provided in all connections.

Pressure plate

Must be moved when the PHE is opened. Therefore, no fixed pipes should be fitted inside the shaded area. Use, for example, a short bend directed sideways.

Note!
Dismantle pipes from the pressure plate and the connection plate(s) so that the pressure plate and the connection plate(s) are free to move along the carrying bar.

Pipe connection

Avoid excessive force on pipe connections.

Caution!
Turning of the connections will damage the gaskets on the end plate and cause leakage.

Fit the pipes so that no tension is transferred to the heat exchanger. Nozzle loads are not permitted.

Pipes connected to the pressure plate and to the connection plates must allow $\pm 1\%$ of the distance from the connection to the frame plate (see the assembly PHE drawing).

Applicable for 3A Standards

Once the unit is in position and the feet have been properly adjusted, it is the responsibility of the end user to seal around the feet with silicone or caulking to fulfil 3A standard.

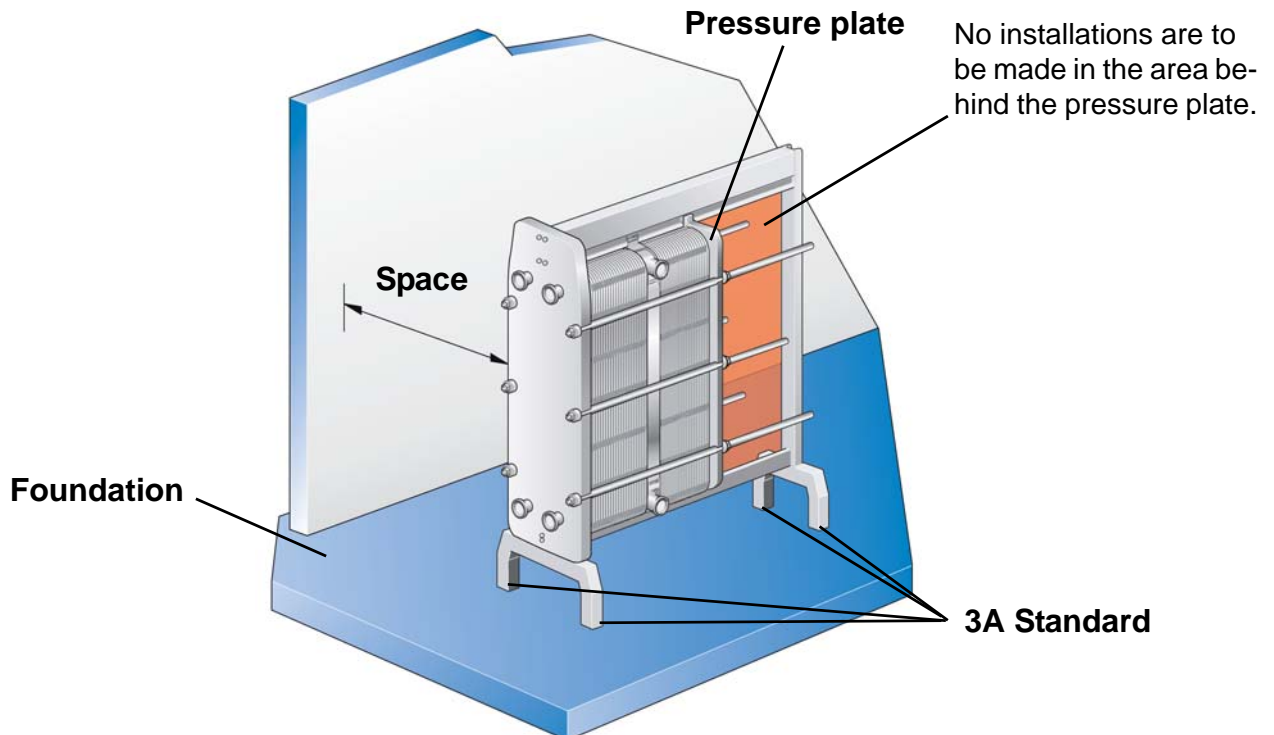

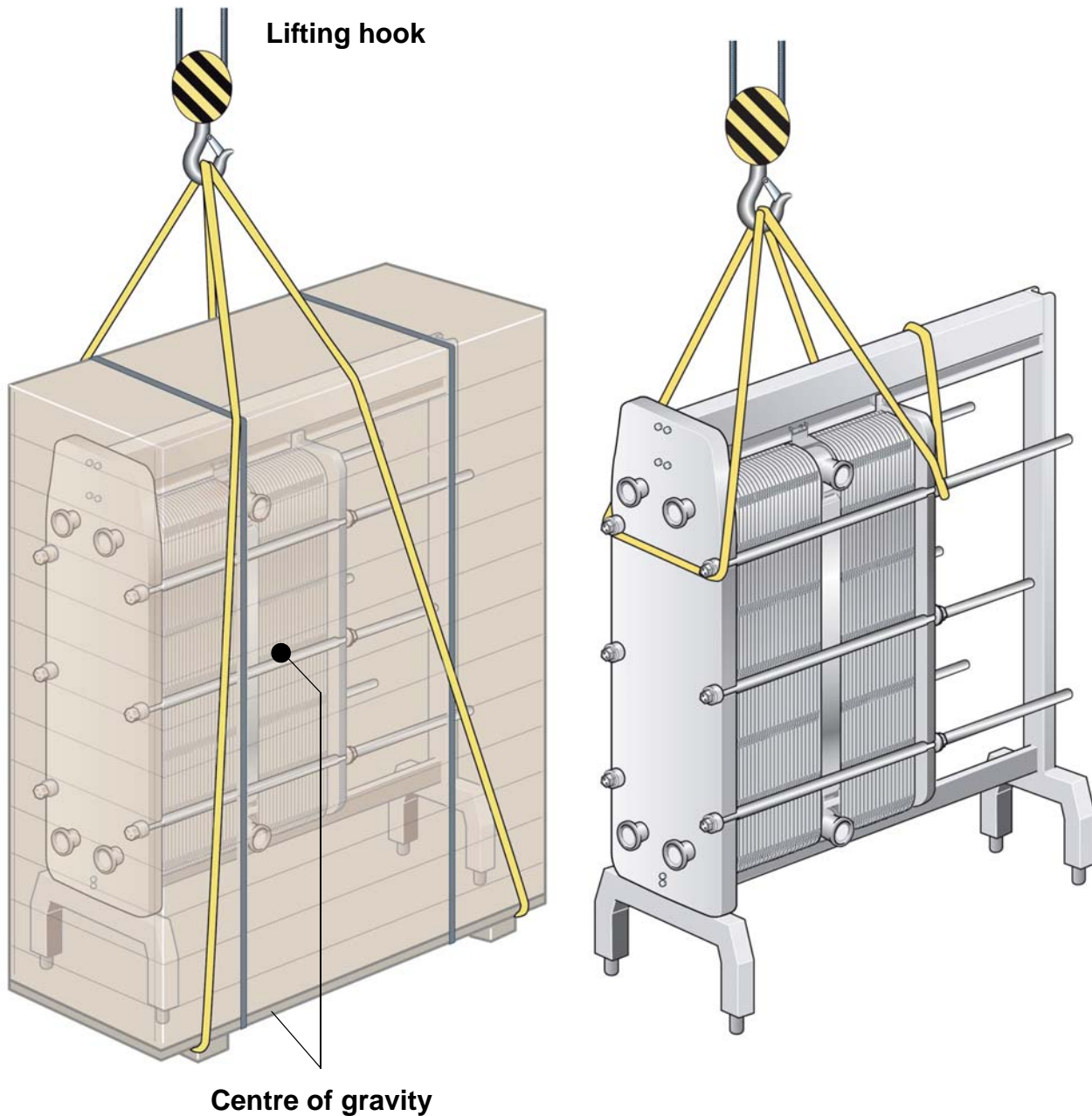

Straps should be used when lifting the PHE. Place straps according to picture.

**Warning!**

Never lift by the connections or the studs around them.

Centre of gravity

The centre of gravity is marked on the sides of the case. The actual centre of gravity is located directly below this mark. Position the lifting hook vertically in line with the mark for centre of gravity.

Raising

EN

This instruction is valid when raising the PHE after delivery from Alfa Laval. Only use a strap approved for the weight of the PHE. Follow the principle of the instruction below.



Caution!

The straps shall be long enough to be able to rotate the PHE without obstruction. Consider especially the space for the support column.

1 Place two timber beams on the floor.

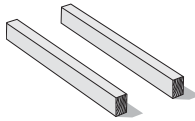

2 Lift the PHE off the pallet using e.g. straps.

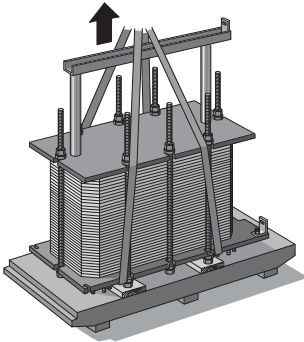

3 Place the PHE on the timber beams.

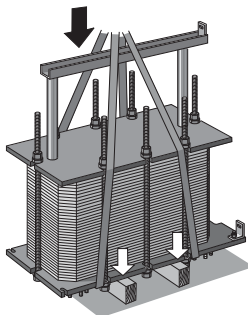

4 Place straps around one bolt on each side.

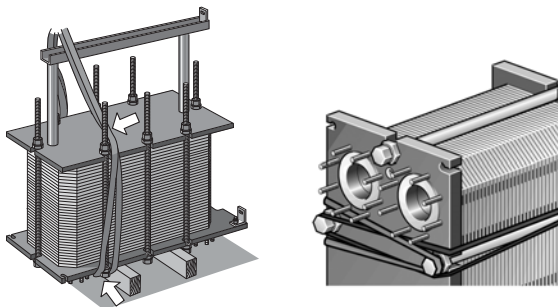

5 Lift the PHE off the timber beams.

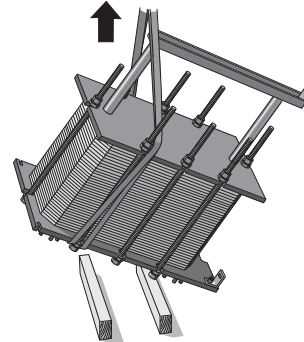

6 Lower the PHE into a horizontal position and place it on the floor.

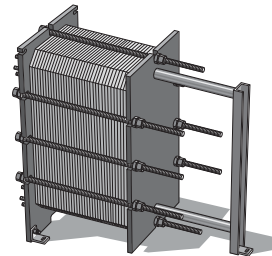

Mounting of stands

Some models of PHE are delivered without the stands mounted. Follow the instruction below.

- 1** On delivery, cover plates are attached on the frame plate and support column in the same positions where the stands shall be mounted.
- 2** Remove the screws, washers and nuts and remove the cover plates.
- 3** Use the same screws, washers and nuts to assemble the stands on the PHE according to the picture.

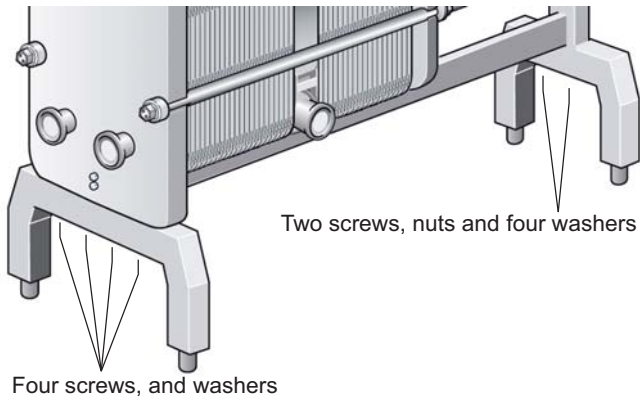

- 4** For Front 15 units, two stabilising bars should also be assembled according to the picture.

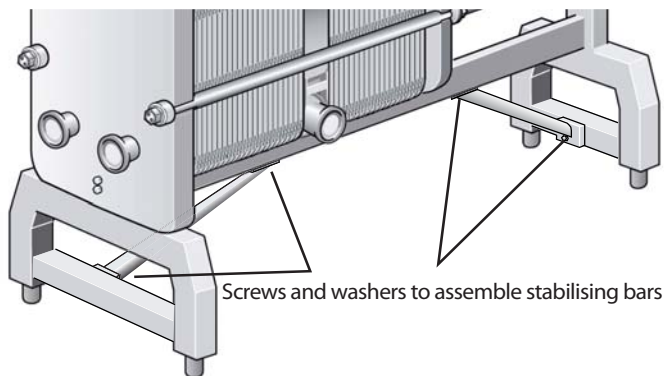

Operation

Start-up

During the start-up, check that there are no visible leakages from the plate pack, valves or piping system.

Note!
If several pumps are included in the system, make sure you know which one should be activated first.

Centrifugal pumps must be started with valves closed and the valves must be operated as smoothly as possible.

Do not run pumps temporarily empty on the suction side.

Note!
Adjustments of flow rates should be made slowly in order to avoid the risk of **pressure surge (water hammer)**. Water hammer is a short lasting pressure peak that can appear during the start-up or shut-down of a system, causing liquids to travel along a pipe as a wave at the speed of sound. This can cause considerable damage to the equipment.

1 Before the start-up, check that all tightening bolts are firmly tightened and that the dimension A is correct, refer to the PHE drawing.

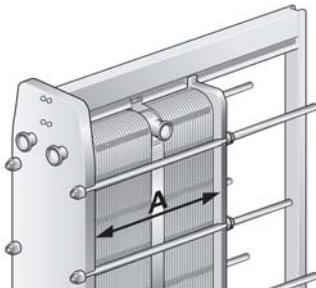

2 Check that the valve is closed between the pump and the unit controlling the system flow rate to avoid pressure surge.

3 If there is a vent valve installed at the exit, make sure it is fully open.

4 Increase the flow rate slowly.

5 Open the air vent and start the pump.

6 Open the valve slowly.

Note!
Avoid rapid temperature changes in the PHE. With media temperatures over 100°C, slowly increase the temperature, preferably at least for one hour.

7 When all the air is expelled, close the air vent.

8 Repeat steps 1 – 7 for the second media.



Unit in operation

Adjustments of flow rates should be made slowly in order to protect the system against sudden and extreme variations of temperature and pressure.

During operation, check that media temperatures and pressures are within the limits stated on the PHE-drawing and identification plate.

Shut-down

Note!

If several pumps are included in the system, make sure you know which one should be stopped first.

- 1** Slowly close the valve controlling the flow rate of the pump you are about to stop.
- 2** When the valve is closed, stop the pump.
- 3** Repeat steps 1–2 for the other side for the second media. Continue with both sides of each section.

4

If the PHE is shut down for several days or longer, it should be drained. Draining should also be done if the process is shut down and the ambient temperature is below the freezing temperature of the media. Depending on the media processed, it is also recommended to rinse and dry the PHE plates and connections.

Maintenance

To keep the PHE in good condition, regular maintenance of the component is required. It is recommended to record all maintenance of the PHE.

The plates need to be cleaned on a regular basis. The frequency depends on several factors such as type of media and temperature. Different methods can be used for cleaning, refer to [“Cleaning – Product side” on page 17](#), [“Cleaning – Non-product side” on page 19](#) or a reconditioning can be performed at an Alfa Laval service centre.

After a long period of use, it can be required to regasket the PHE by exchanging the gaskets. Refer to [“Regasketing” on page 24](#).

Other maintenance that should be performed regularly:

- Keep carrying bar and guiding bar clean with paraffin oil.
- Keep the tightening bolts cleaned.
- The stainless steel surfaces of the frame plate, the pressure plate and connection plates are glass blasted. Clean with a cloth wetted by paraffin oil. Do not degrease the surface!
- Lubricate the threads of the tightening bolts with an EP (extreme pressure) grease. For example, use Gleitmo 800 or its equivalent. Grease the suspension wheels on the pressure plate and the connection plates.

Cleaning – Product side

Immediately after a production cycle, the product side is normally cleaned through the circulation of acid and/or lye as a built-in sequence in the production cycle.

Note!
After the first test run of the product, the PHE should be cleaned following a cleaning programme applicable to the product in question. The PHE should then be opened, refer to [“Opening” on page 20](#), and the plate surfaces carefully inspected. The cleaning results should be checked at regular intervals.

Warning!
Use proper protective equipment, such as safety boots, safety gloves and eye protection, when using the cleaning agents.

Warning!
Corrosive cleaning liquids. Can cause serious injuries to skin and eyes!

Sterilisation is performed immediately before starting the next production cycle. Refer to [“Sterilisation” on page 17](#).

Flow rates

The flow rate during the cleaning of the product side should always be at least the same as the production's

flow rate. An increased flow rate may be required in some cases e.g. in milk sterilisation and the processing of viscous liquids or liquids containing particles.

Recommended limits for cleaning solutions

- 5% by volume AlfaCaus at max. 70°C.
- 0.5% by weight acid solution at max. 70°C.

Sterilisation

The methods of sterilisation below are recommendations. Instructions for sterilisation can also be included in the documentation of the complete system delivered with the PHE as one part.

Method	Instructions
By heat	Circulate water of 90°C until all parts of the system have been kept at the required temperature for at least ten minutes.
Chemically by hypochlorite	Before introducing the hypochlorite solution, make sure that the equipment is clean, has cooled down and is free from deposits and that no acid residues are left. Gradually add 100 cm ³ of hypochlorite solution, containing max. 150 g/l of active chlorine to 100 l of circulating water at a max. temperature of 20°C. Treat for five minutes, up to a maximum of 15 minutes. Rinse well after sterilisation.



EN

Typical cleaning programmes

Consult your local Alfa Laval representative for advice on suitable cleaning programmes.

Products rich in protein		
Coolers		Pasteurisers and other heaters
Daily	Weekly	Daily
Rinsing 5 min Lye 20 min Rinsing 10 min Stop Sterilisation 10 min	Rinsing 5 min Acid 15 min Rinsing 5 min Lye 20 min Rinsing 10 min Stop Sterilisation	Rinsing 5 min Acid 15 min Rinsing 5 min Lye 20 min Rinsing 5 min ^a Acid 15 min ^a Rinsing 10 min Stop

- a. The need for an additional acid cycle in order to remove calcium carbonate scaling depends on the product. In many cases, it is possible to carry out cleaning at considerably longer intervals. Sometimes, it is possible to eliminate acid cleaning altogether.

Products poor in protein	
High content of insoluble components, e.g. nectar and tomato juice	
Daily	Weekly
Rinsing 10 min Lye 30 min Rinsing 10 min Stop Sterilisation 10 min	Rinsing 10 min Lye 30 min Rinsing 5 min ^a Acid 15 min ^a Rinsing 10 min Stop Sterilisation 10 min

Products poor in protein	
Low content of insoluble components, e.g. beer and wine	
Daily^a	Weekly
Rinsing 5 min Lye 15 min Rinsing 10 min Stop Sterilisation 10 min	Rinsing 5 min Lye 15 min Rinsing 5 min ^a Acid 15 min ^a Rinsing 10 min Stop Sterilisation 10 min

- a. In some cases, where the risk of growth of micro-organisms is low, it is possible to eliminate daily cleaning and replace it with the following procedure: Rinsing 20 min – Stop – Sterilisation 20 min.

Applicable for 3A Standards

When used in a processing system to be sterilised, the system shall be provided with an automatic shut-down if the product pressure becomes less than that of the atmosphere and not be restarted without re-sterilisation (see paragraph D10.3). The information plate will then state that the PHE “is” designed for steam sterilisation.

Cleaning – Non-product side

EN

The cleaning-in-place (CIP) equipment permits cleaning of the PHE without opening it. The purpose of cleaning with CIP is as follows:

- Cleaning of fouling and descaling of lime deposits
- Passivation of cleaned surfaces to reduce susceptibility to corrosion
- Neutralisation of cleaning liquids before draining.

Follow the instructions of the CIP equipment.

Warning!
Use proper protective equipment, such as safety boots, safety gloves and eye protection, when using the cleaning agents.

Warning!
Corrosive cleaning liquids. Can cause serious injuries to skin and eyes!

CIP equipment

Contact the Alfa Laval sales representative for the size of CIP equipment.



Cleaning liquids

<i>Liquids</i>	<i>Description</i>
AlfaCaus	A strong alkaline liquid, for removing paint, fat, oil and biological deposits.
AlfaPhos	An acid cleaning liquid for removing metallic oxides, rust, lime and other inorganic scale. Contains re-passivation inhibitor
AlfaNeutra	A strong alkaline liquid for the neutralisation of AlfaPhos before drainage.
Alfa P-Neutra	For the neutralisation of Alfa P-Scale.
Alfa P-Scale	An acidic powder cleaner for the removal of primary carbonate scale but also other inorganic scale.
AlfaDescalent	A non-hazardous acidic cleaning agent for the removal of inorganic scale.
AlfaDegreaser	A non-hazardous cleaning agent for the removal of oil, grease or wax deposits. Also prevents foaming when using Alpacon Descaler.
AlfaAdd	AlfaAdd is a neutral cleaning strengthener designed to be used with AlfaPhos, AlfaCaus and Alfa P-Scale. 0.5–1 vol% is added to the total diluted cleaning solution to provide better cleaning results on oily and fatty surfaces and where biological growth occurs. AlfaAdd also reduces any foaming.

If CIP cannot be done, cleaning must be done manually. Refer to section [“Manual cleaning of opened units”](#) on page 22.

Chlorine as a growth inhibitor

Chlorine, commonly used as a growth inhibitor in cooling water systems, reduces the corrosion resistance of stainless steels (including high alloys like Alloy 254).

Chlorine weakens the protection layer of these steels making them more susceptible to corrosion attacks than they otherwise would be. It is a matter of time of exposure and concentration.

In all cases where the chlorination of non-titanium equipment cannot be avoided, your local representative must be consulted.

Water of more than 300 ppm Cl ions may not be used in the preparation of cleaning solutions.

Note!

Titanium is not affected by chlorine.

Opening and closing

Opening

Note!

Before opening the PHE, check the warranty conditions. If in any doubt, contact the Alfa Laval sales representative. Refer to "Warranty conditions" on page 2.

1 Shut down the PHE.

2 Close the valves and isolate the PHE from the rest of the system.



Warning!

If the PHE is hot, wait until it has cooled down to about 40 °C (104 °F).

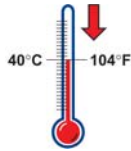

Warning!

If necessary, use proper protective equipment, such as safety boots, safety gloves and eye protection, depending on the type of media in the PHE.



3 Drain the PHE.

4 Remove the protection sheets, if any.

5 Dismantle pipes from the pressure plate and the connection plate(s) so that the pressure plate and the connection plate(s) are free to move along the carrying bar.

6 Inspect the sliding surfaces of the carrying bar and wipe clean and grease.

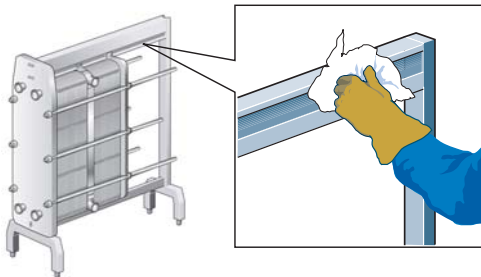

7

Mark the plate assembly on the outside by a diagonal line.

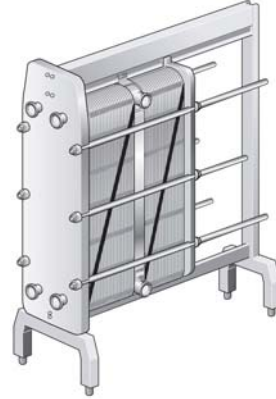

8

Measure and note down the dimension A.

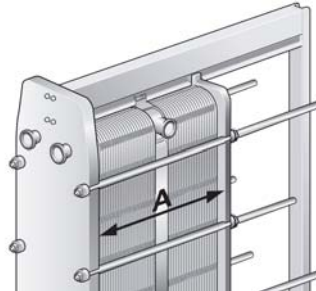

9

Loosen and remove the bolts as shown in the figures below.

Remove the bolts

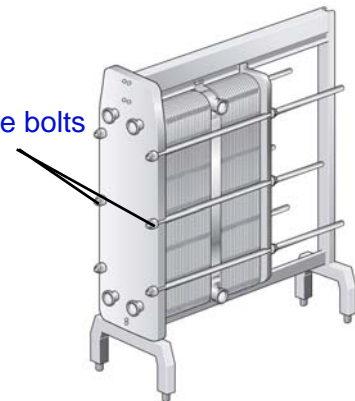

Note!

Brush the threads of the tightening bolts with a steel wire brush and then grease the threads before loosening them.

10 Use the remaining four bolts, equipped with bearing boxes, to open the PHE. During the opening procedure, keep the frame plate and pressure plate always in parallel. Skewing of the pressure plate during opening must not exceed 10 mm (2 turns per bolt) across the width and 25 mm (5 turns per bolt) vertically

Loosen the four bolts evenly in the numbered order, 1-2-3-4. Continue alternately until all reaction forces of the plate pack have disappeared. Then remove the bolts.

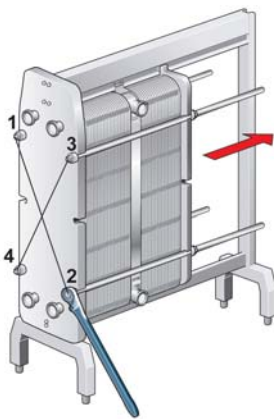

If plates are to be numbered, do this before removing the plates.

Plates need not be removed if cleaning is done using only water, i.e. without a cleaning agent.

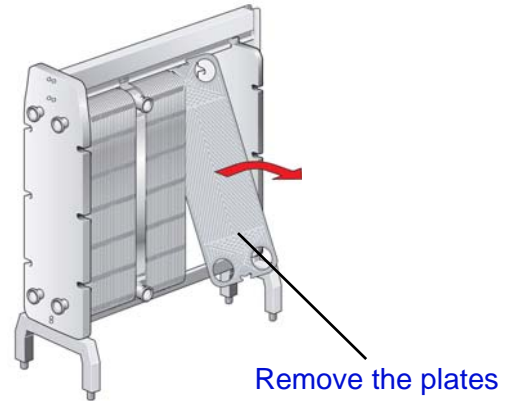

Warning! The plate pack may still contain a small residual amount of liquid after draining. Depending on the type of product and type of installation, special arrangements, e.g. drainage box, may be necessary to avoid damages to personnel and equipment.

11 Open the plate pack by letting the pressure plate glide on the carrying bar.

Warning! To avoid hand injuries owing to sharp edges, protective gloves should always be worn when handling plates and protection sheets.

Note! Plates should be numbered, do this before removing the plates.



EN

Manual cleaning of opened units

Caution!
Never use hydrochloric acid with stainless steel plates. Water of more than 330 ppm Cl may not be used for the preparation of cleaning solutions. It is very important that aluminium carrying bars and support columns are protected against chemicals.

Note!
Be careful not to damage the gasket during manual cleaning.

Deposits removable with water and brush
Plates do not need to be removed from the PHE during cleaning.

Warning!
If necessary, use proper protective equipment. Consider risks such as loose particles and the kind of media that has been used in the PHE.

1 Start cleaning when the heating surface is still wet and the plates are hanging in the frame.

2 Remove deposits using a soft brush and running water.

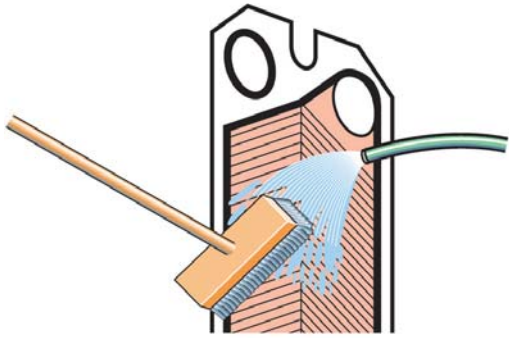

3 Rinse with water using a high pressure hose.

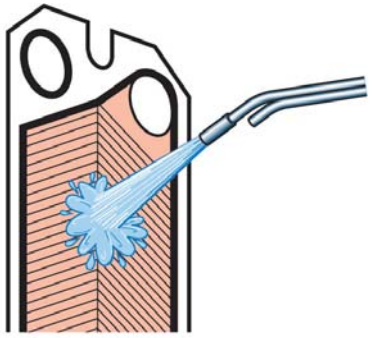

Deposits not removable with water and brush
Plates must be removed from the PHE during cleaning. Choice of cleaning agents, refer to "Cleaning liquids" on page 19.

Warning!
Use proper protective equipment, such as safety boots, safety gloves and eye protection, when using the cleaning agents.



Warning!
Corrosive cleaning liquids. Can cause serious injuries to skin and eyes!



1 Brush with cleaning agent.

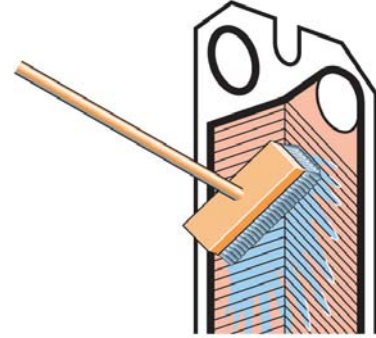

2 Rinse immediately with water.

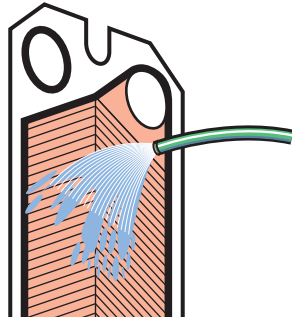

Note!
Long exposure to the cleaning agents can damage the gasket glue.

Closing

- 1** Check that all gaskets are correctly positioned in the grooves. Also, check the hanger device is not damaged.
- 2** Brush the threads of the bolts clean, using a steel wire brush. Lubricate the threads with a thin layer of grease, e.g. Gleitmo 800 or its equivalent.

Note!
If the gasket is wrongly positioned, it will show by the fact that it rises out of the gasket groove or that it is positioned outside the groove.

- 3** Insert the plates in alternate directions and with the gaskets turned towards the frame plate or pressure plate as specified on the plate hanging list. Use the marked line that was made when the PHE was opened, refer to step 7 in "Opening" on page 20.

- 4** Press the plate pack together. Position the four bolts according to the figure below.

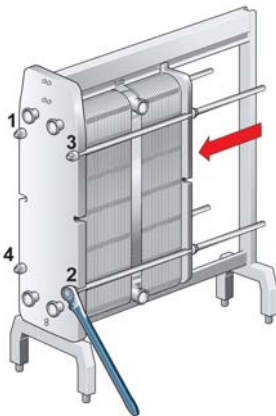

Tighten the four bolts (1-2-3-4) until the reaction force of the plate pack can be noticed. Make sure that the frame and pressure plates are in parallel during the closing procedure.

- 5** Tighten the four bolts evenly in the numbered order, 1-2-3-4. Continue alternately until dimension A has been reached.

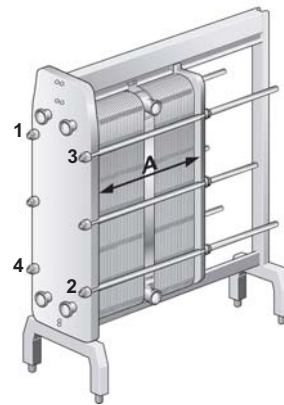

- 6** If the plate pack has been marked on the outside, check this (see step 7 in section "Opening").

If the plates are correctly assembled (A/B/A/B etc.), the edges form a "honeycomb" pattern, see picture below.

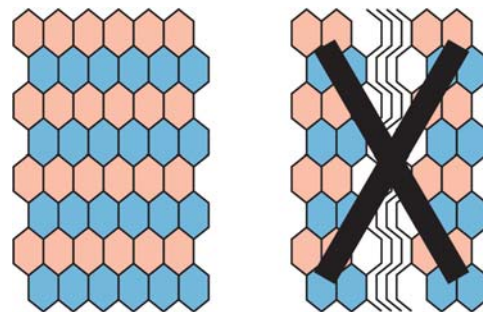

- 7** Mount the remaining bolts and check measurement A on both sides, top and bottom.

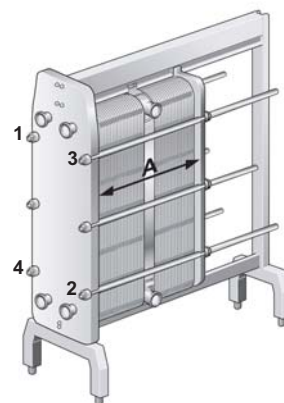

- 8** Mount protection sheets (if provided).

- 9** Connect pipes.

- 10** If the PHE does not seal when measurement A has been reached, it can be tightened further to A minus 0.5%.

EN Pressure test after maintenance

Before the start-up of production, whenever plates or gaskets have been removed, inserted or exchanged, it is strongly recommended to perform a pressure test to confirm the internal and external sealing function of the PHE. In this test, one media side at a time must be tested with the other side open to the ambient pressure. All sections of the same side must be tested simultaneously.



Caution!

The pressure testing shall be performed at a pressure equal to the operating pressure of the actual unit but never above the design pressure as stated on the name plate.

The recommended test time is 10 minutes for each media.

Please consult the local office/representative of the supplier for advice on the pressure testing procedure.

Regasketing

Note!

For Front 8-WS and Front 15, you must perform actions in addition to the instructions below to make the gaskets seal properly. Contact your Alfa Laval representative for advice.

The procedures below concern field gaskets, ring gaskets and end gaskets.

Note!

Before removing the old gaskets, check how they are attached.

Clip-on

1

Open the PHE, refer to [“Opening” on page 20](#).

Note!

Before opening the PHE, check the warranty conditions. If in any doubt, contact the Alfa Laval sales representative. Refer to [“Warranty conditions” on page 2](#).

2

Remove the old gasket with the plate still hanging in the frame.

3

Make sure that all sealing surfaces are dry, clean and free of foreign matter such as fat, grease or similar.

4

Check the gasket and remove rubber residual before attaching it.

Note!

Especially the end plate gasket!

5

Attach the clip-on gasket to the plate. Slip the gasket tabs under the edge of the plate.

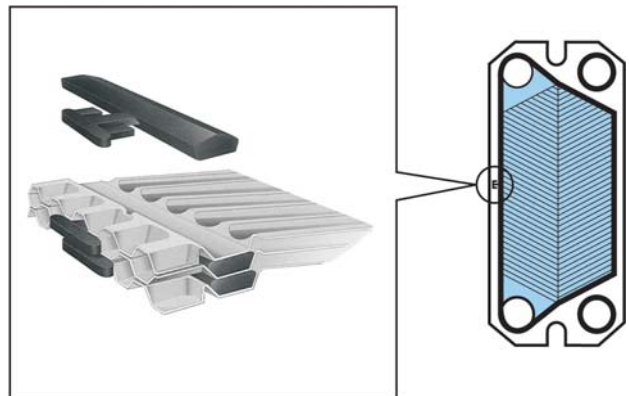

Note!

Make sure the two gasket prongs are in the correct position.

6

Repeat the procedure until all plates that are needed to be regasketed are done. Close the PHE according to [“Closing” on page 23](#).